



# **Hills Rotary Folding Hoists**

## **Polycore Line Replacement Product Manual**

**70m of grey Polycore line**

**Suitable for the following Hills branded  
Rotary Clothesline models:**

Foldaline 1  
Foldaline II  
Foldaline 11A  
Foldaline Prewired  
Foldaline Prewired with Line Tensioning  
Foldaline Compact  
Foldaline Standard 52

Drymaster 32  
Drymaster 42

Courtyard Compact

Villa Everyday  
Villa Family  
Villa Deluxe  
Villa Deluxe Plus

Traditional 42

Rotary 400  
Rotary 450  
Rotary 500

Rotary 6  
Rotary 7  
Rotary 8

Rotary 6 Premium  
Rotary 7 Premium  
Rotary 8 Premium

Everyday Villa 37  
Everyday Villa 47

# Foldaline 1, 11 and 11A Models

## Step 1 – Installing New Line

- 1.1 Open up the Hoist and lock into position.
- 1.2 Remove the old polycore line from your clothesline.
- 1.3 Unwind the replacement line and lay out on the ground to prevent tangles.
- 1.4 Thread the line through the four end caps as shown in **Fig. 1** and cut off leaving 200mm each end to tie off at point A.
- 1.5 Pull the line tight and ensure that the arms are square to each other before tying off as per **Fig. 2**.

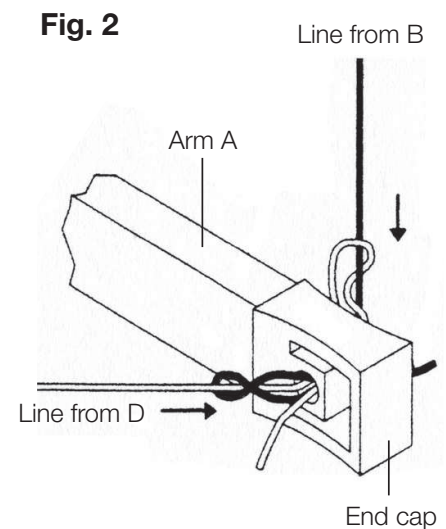
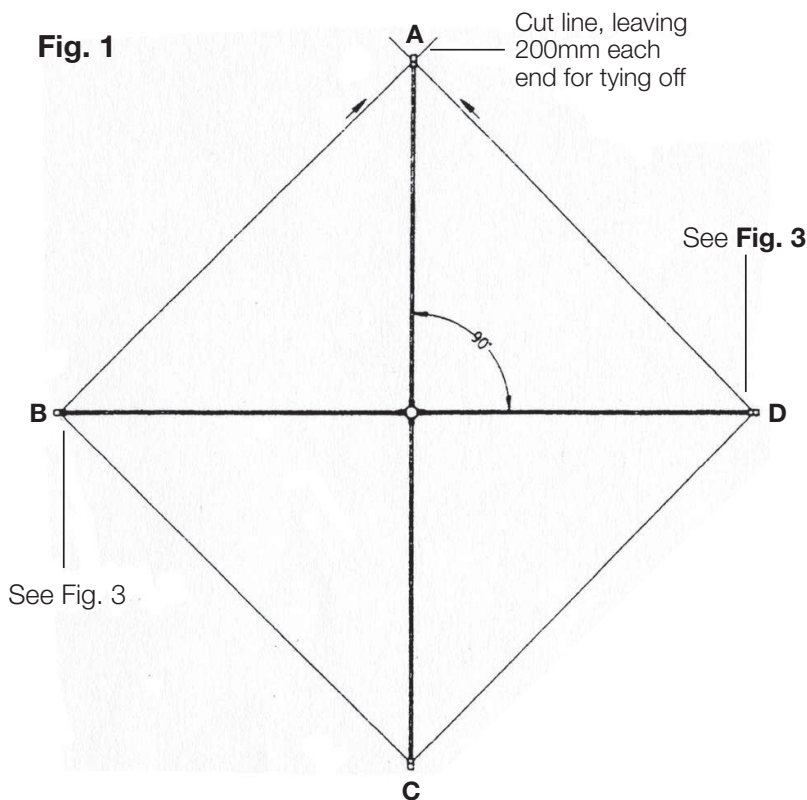

- 1.6 Cut two pieces of line 300mm long from the coil. Square up the arms and with the two pieces of line, tie the outer line to the end caps at points B and D as described in **Fig. 3**. This will ensure that the arms will stay square.

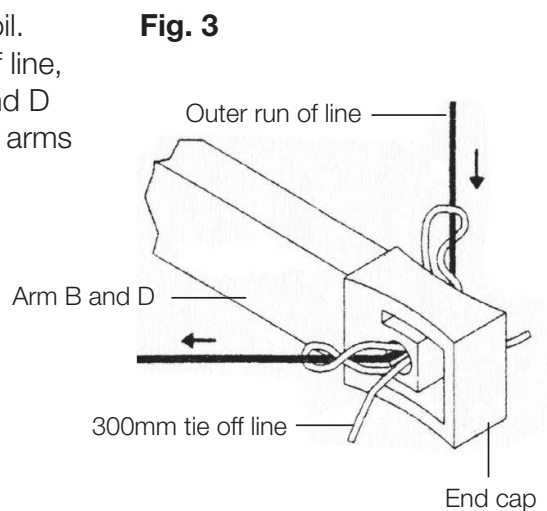

## Step 1 – Installing New Line continued

- 1.7 Take the end of the main coil of line and tie it off at point C as shown in **Fig. 4** and **Fig. 5**. This is the start point.
- 1.8 Run the line along the arm towards the centre of the hoist to the first line grommet. See **Fig. 5**. Thread the free end of the line through each corresponding grommets on arms B, A and D and back through the first grommet.
- 1.9 Pull the line tight and run the free end of the line down the arm to the second grommet and repeat as in **Fig. 4 and 5**.



Pull the line carefully through the line grommets to avoid damage

- 1.10 Repeat this process until you have reached the finish point as shown in **Fig. 4** with the end of the line.

- 1.11 **Do not** tie off the line at this time. First the line must be tensioned.

**Fig. 4**

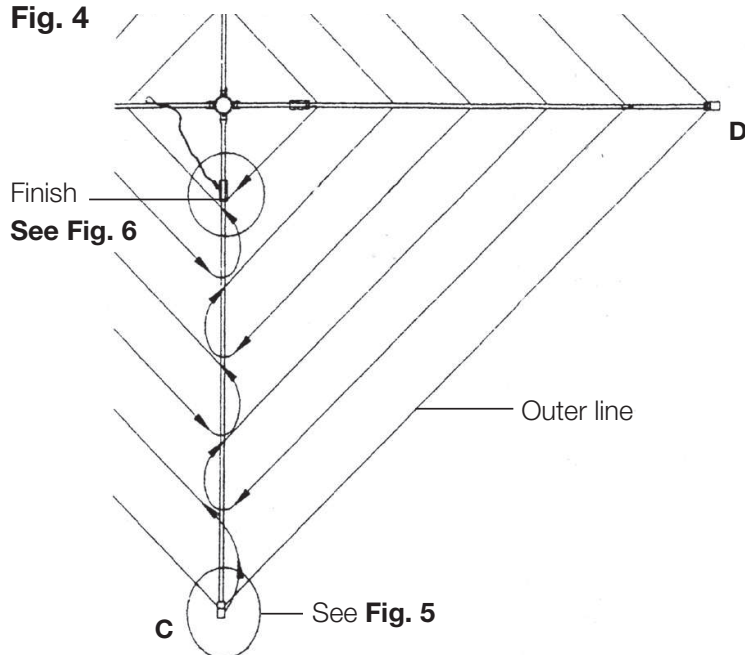

**Fig. 5**

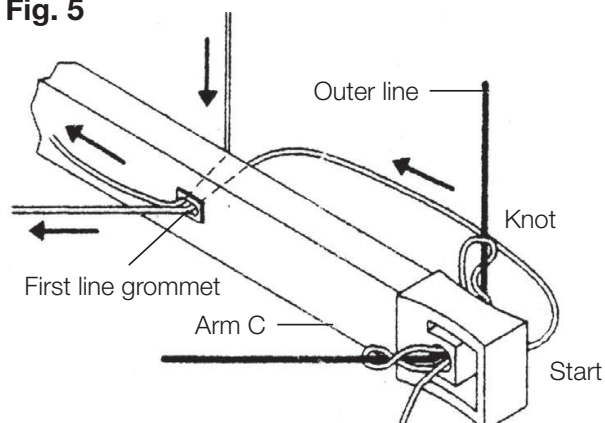

## Foldaline 1, 11 and 11A Models

### Step 2 – Tensioning the line

- 2.1** Start at the first line grommet. See **Fig. 5**. Pull the line tight to remove any slackness. Work your way around the hoist in the same direction as you wired it until you reach the last grommet. See **Fig. 4**.

### Step 3 – Tying the line off

- 3.1** Pull the line tight through the last grommet and tie off as shown in **Fig. 6**. Do not cut the line off at this point.
- 3.2** Fold up the hoist. Open it again and lock into position to check for over-tightness. Adjust line tension if necessary.

### Step 4 – Arm tie off line

The arm tie off line is used to secure the hoist arms for storage.

- 4.1** Cut the line 1 metre from the tie off knot. Thread the end between the arm and the line at the point shown in **Fig. 6**.
- 4.2** Fit the cover onto the line. Tie the line tie off clip to the end of the line and slip the cover over the knot to secure.
- 4.3** Your hoist is now ready for use.

**Fig. 6**

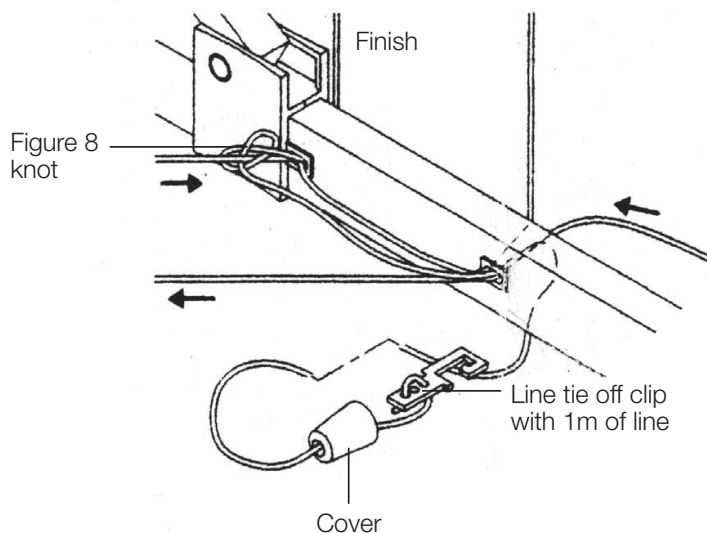

# Foldaline Prewired, Foldaline Line Tensioning, Compact, Standard, Villa, Drymaster, Traditional Models

## Step 1 – Removing Old Line

1.1 Open up the hoist and lock into position.



Take notice as to how your hoist is wired before removing the old polycore line.

1.2 Remove the wedges from the end caps by inserting a 5mm pin through the hole in the underside of the end cap and tapping up with a hammer. See **Fig. 7**.

1.3 Untie/cut the knots at the start and finish points. See **Fig. 10**.

1.4 Untie/cut the knots and remove the line tie off clip. See **Fig. 11**.

1.5 Cut the line approximately 300mm each side of the line tensioners (where fitted). See **Fig. 8**.

1.6 Remove the line from the line tensioners (where fitted) by pulling it between the tensioner base and the spool a half turn at a time. See **Fig. 8**.

1.7 Use the tensioner key to line up the slots in the spool (where fitted) with those in the tensioner body.

1.8 Remove the remaining line by pulling it through the line clips. See **Fig. 9**.

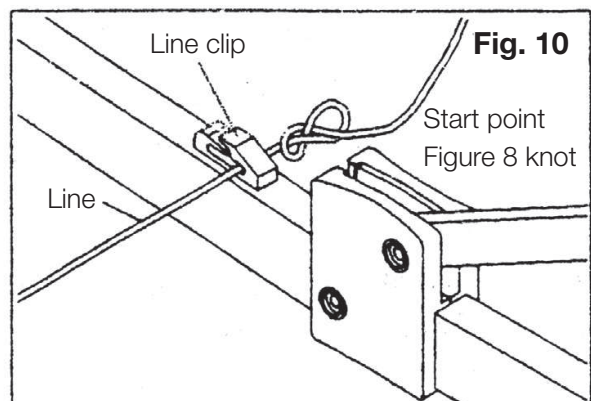
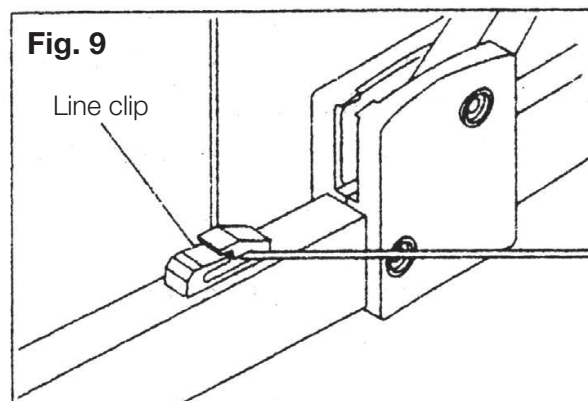
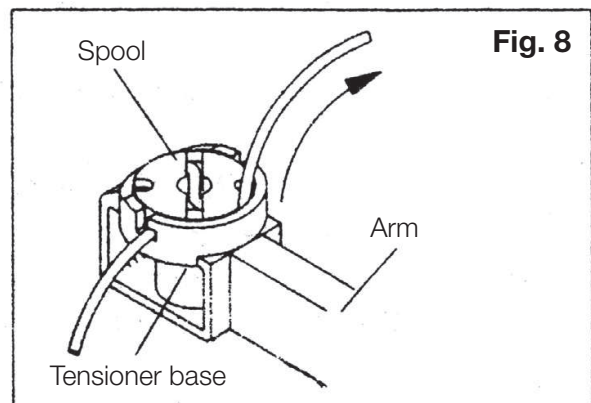
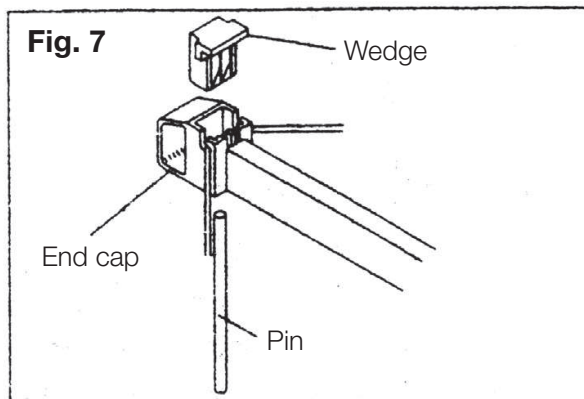

## Step 2 – Installing New Line

Unwind the replacement line and lay out on the ground to prevent tangles.

- 2.1** Tie a figure 8 knot 1m from the end of the new line and snap it through the first line clip opposite the line tensioning arm (if fitted). See **Fig. 10**.
- 2.2** Attach the line to the next line clips and tensioners in succession until you return to the start point. Follow the directions in **Fig. 11**.



At this point check that the hoist arms are square to each other and not pulled out of shape.

- 2.3** Snap the line through the start line clip and pull tight. Thread the line out along the arm to the next line clip. Repeat as previous until you reach the end, which is on the end of the arm from which you started.
- 2.4** Pull the lines tight by hand starting from the inside and working outward. Make sure that the arms are square to each other. Tie off the line as per instructions in **Fig. 11** and replace the locking wedges.
- 2.5** Insert the tensioner key into the line tensioners (if fitted) and rotate one quarter turn clockwise to lock the line in position.
- 2.6** Allow the line to settle before tensioning using the line tensioners.
- 2.7** Replace the line tie off clip on the end of the 1m long tie off line.

# Foldalene Prewired, Foldalene Line Tensioning, Compact, Standard, Villa, Drymaster, Traditional Models

**Fig. 11**

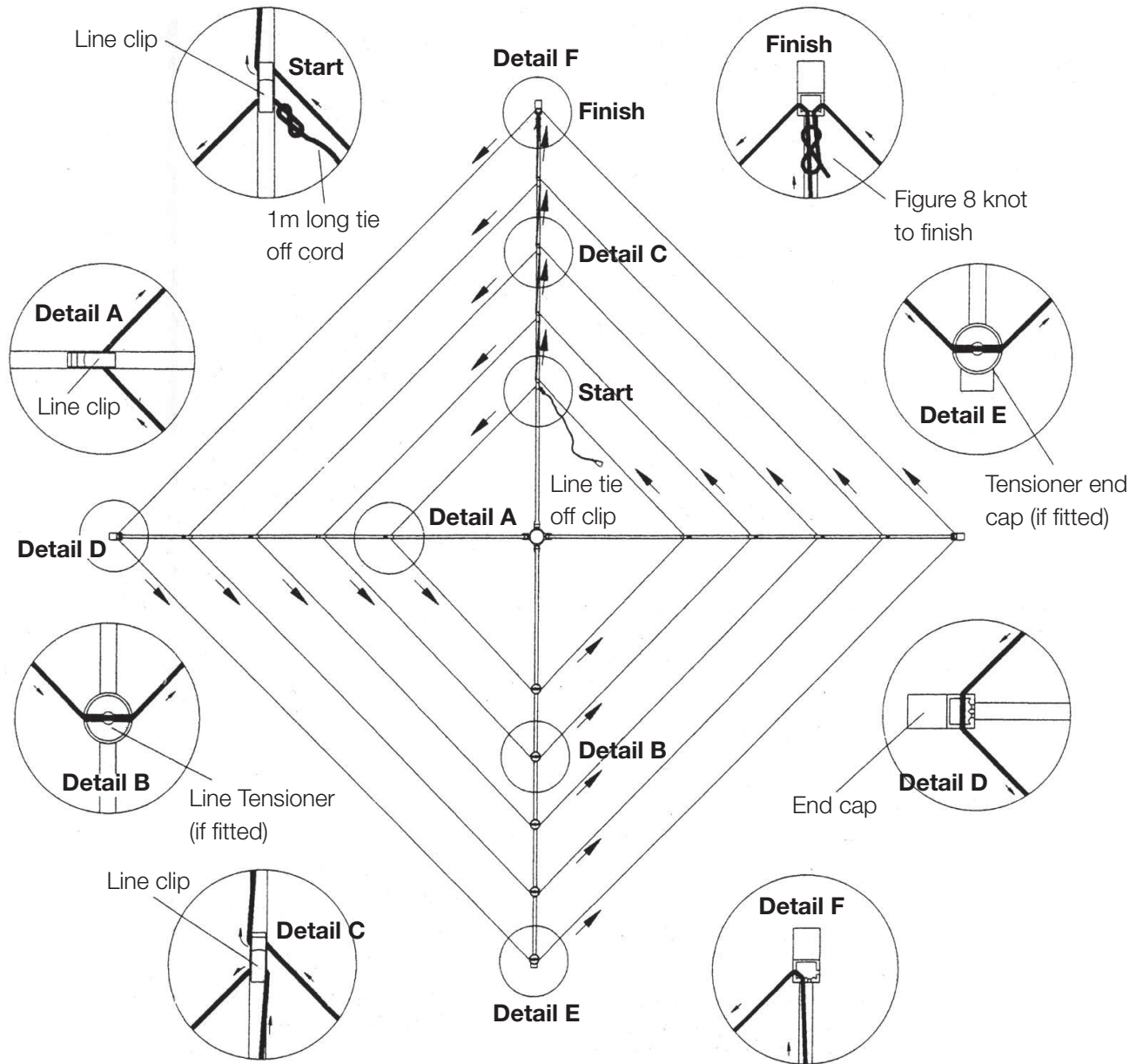



## Step 1 – Removing Old Line



Take notice as to how your hoist is wired before removing the old polycore line.

Protect your eyes when removing and replacing plastic components.



The line replacement pack can be used to replace all lines on your Rotary Hoist. Replace one section at a time beginning with the four outside lines first. Make sure that the arms of the hoist remain square to each other.

- 1.1 Open hoist and lock into position.
- 1.2 Rotate the line cover anti-clockwise until it is off of the line tensioner on one end. Repeat for the other end, which needs replacing.
- 1.3 Untie the polycore line from the tensioners and discard. Do not discard the line covers.
- 1.4 Repeat for the remaining line segments.

## Step 2 – Replacing New Line

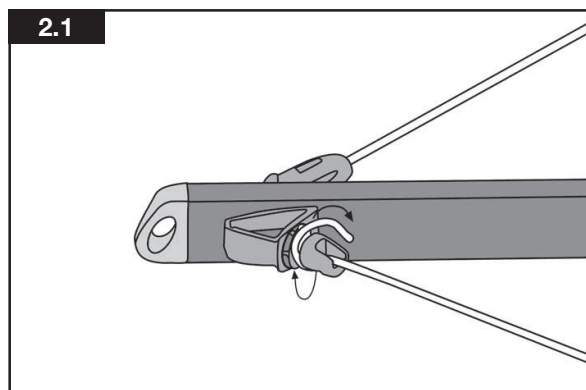

Pull line through tensioner. Loop line around back groove of the tensioner and pull tight to prevent line from slipping.

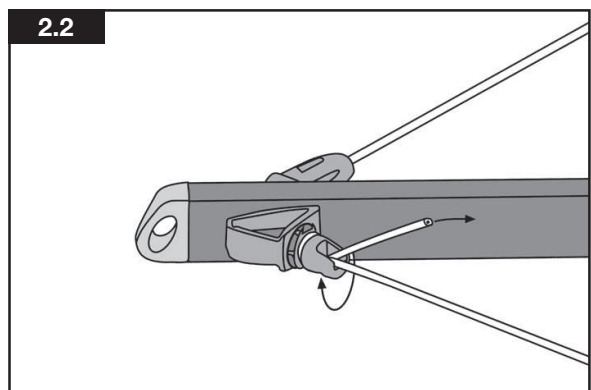

Feed the line up and through the front slot of the tensioner and pull tight.

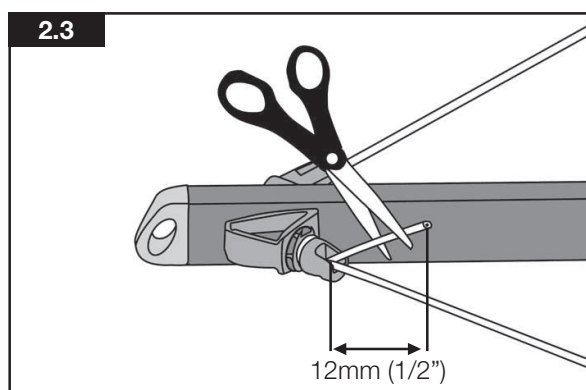

Using scissors carefully trim off excess line, leaving approximately 12mm (1/2").

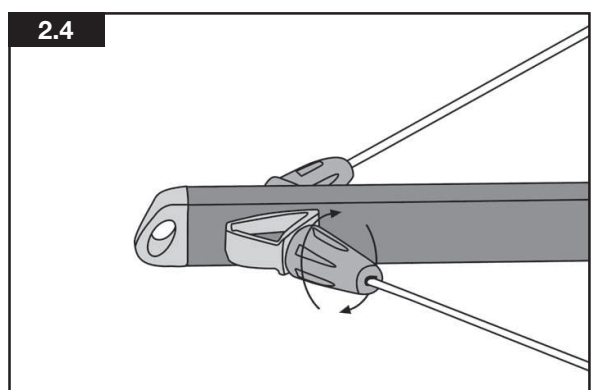

Re-attach the line cover by rotating clockwise. This will obscure the small piece of excess line remaining. Repeat on the other end. Ensure line is tensioned.



Fold hoist up and down to ensure hoist is not over tensioned and the lower cross engages with the locking collar



## Step 1 – Removing Old Line



Take notice as to how your hoist is wired before removing the old polycore line.

Protect your eyes when removing and replacing plastic components.



The line replacement pack can be used to replace all lines on your Rotary Hoist. Replace one section at a time beginning with the four outside lines first. Make sure that the arms of the hoist remain square to each other.

- 1.1 Open hoist and lock into position.
- 1.2 Remove the line covers off the tensioners. Covers are simply clipped in place and can be levered off to remove.
- 1.3 Untie the polycore line from the tensioners and discard. Do not discard the line covers.
- 1.4 Repeat for the remaining line segments.

## Step 2 – Replacing New Line

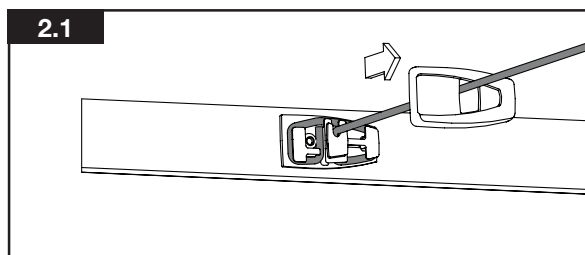

Remove cover cap.

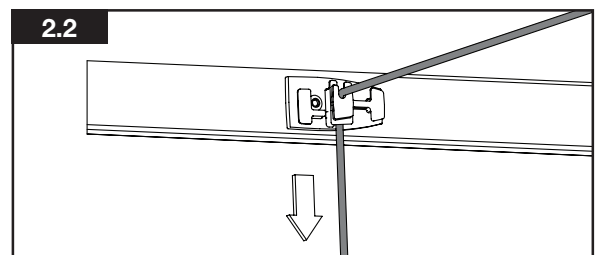

Undo line from tensioner path. Insert new line and pull downwards.

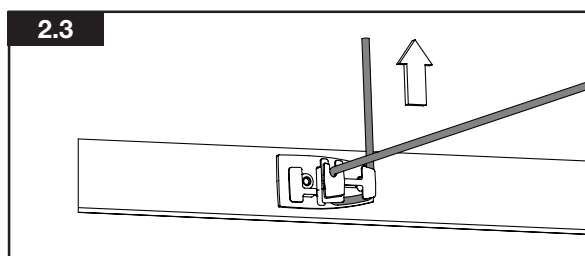

Start wrapping the line around the tensioner securing it in the anchor points.

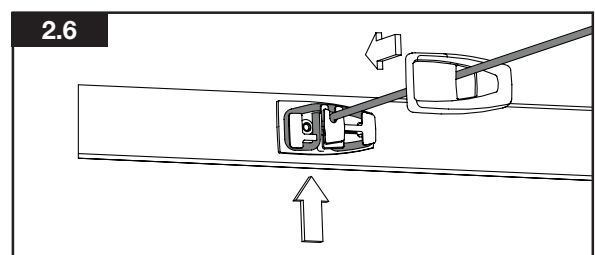
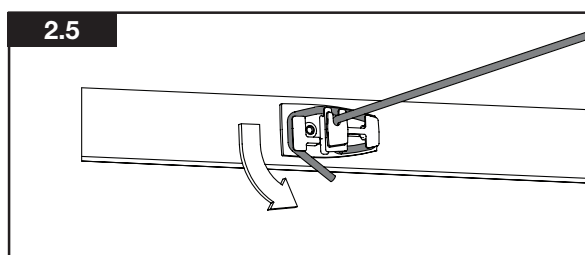
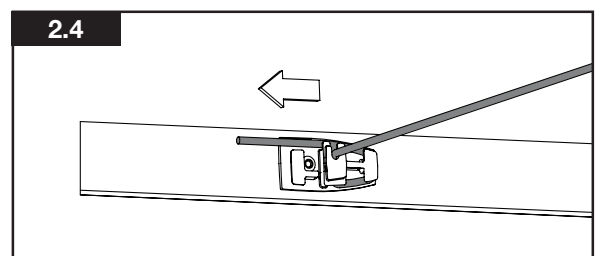

When line is clipped into final anchor point, cut off any excess line so it fits inside tensioner as shown. Replace cap to finish. Repeat on the other end. Ensure line is tensioned.



Fold hoist up and down to ensure hoist is not over tensioned and the lower cross engages with the locking collar

## Rotary Premium 6, 7 and 8 Models

### Step 1 – Removing Old Line



Take notice as to how your hoist is wired before removing the old polycore line.

Protect your eyes when removing and replacing plastic components.



The line replacement pack can be used to replace all lines on your Rotary Hoist. Replace one section at a time beginning with the outside line first. Make sure that the arms of the hoist remain square to each other.

- 1.1** Open hoist and lock into position.
- 1.2** Locate the tensioner arm. This is highlighted by an arrow on the bottom of the arm cross. Remove the line covers off the tensioners. Covers are simply clipped in place and can be levered off to remove.
- 1.3** Untie the polycore line from the tensioners and discard. Do not discard the line covers.
- 1.4** Repeat for the remaining line segments.

## Step 2 – Replacing New Line

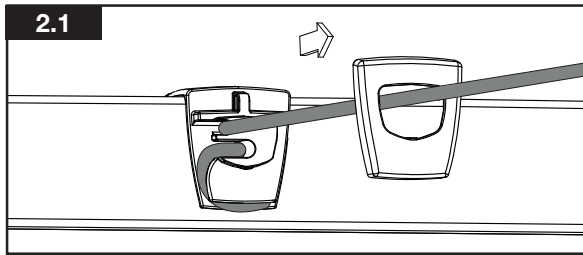

2.1  
Locate the tensioner arm. This is highlighted by an arrow on the bottom of the arm cross. Remove cover cap.

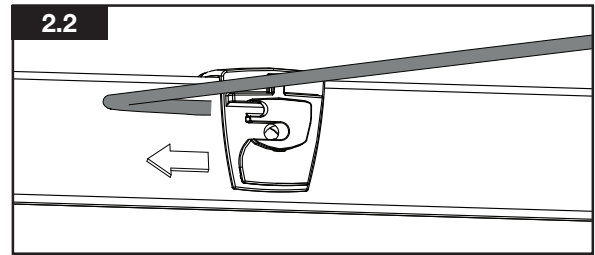

2.2  
Pull line out from tensioner.

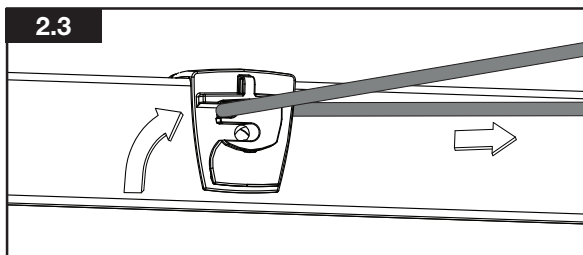

2.3  
Undo line from tensioner path. Insert new line.

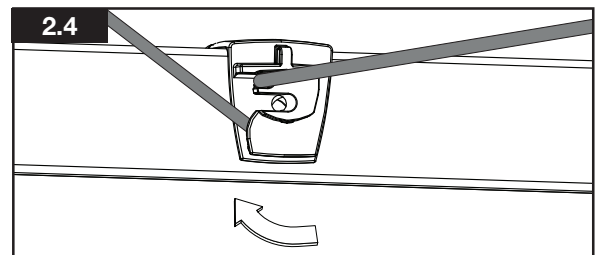

2.4  
Swing the line back under the tensioner lip to secure.  
**TIP:** Keep pressure on bottom left edge to stop tension loss.

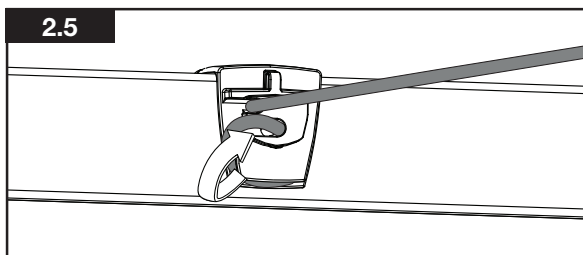

2.5  
Feed line back into arm through central hole. Cut off excessive line if required prior to putting into arm.

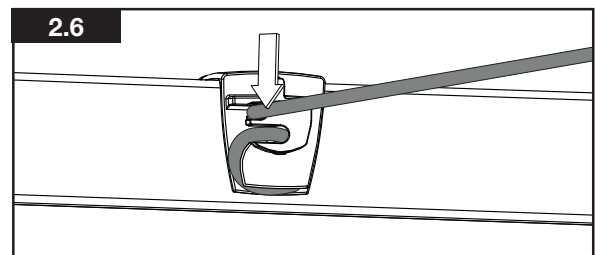

2.6  
Push line firmly into arm to give a flush result.

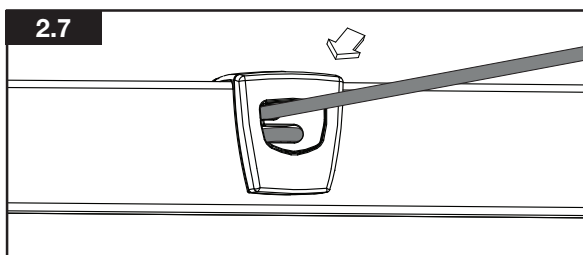

2.7  
Replace cover when finished. Thread line through other arms until you return to the tensioner arm. Fit line into tensioners as previously done. Ensure line is tensioned. Replace cover cap.



Fold hoist up and down to ensure hoist is not over tensioned and the lower cross engages with the locking collar

## Step 1 – Removing Old Line



Take notice as to how your hoist is wired before removing the old polycore line.

Protect your eyes when removing and replacing plastic components.



The line replacement pack can be used to replace all lines on your Rotary Hoist. Replace one section at a time beginning with the outside line first. Make sure that the arms of the hoist remain square to each other.

- 1.1 Open hoist and lock into position.
- 1.2 Untie the polycore line from the tensioners and discard.
- 1.3 Repeat for the remaining line segments.

## Step 2 – Replacing New Line

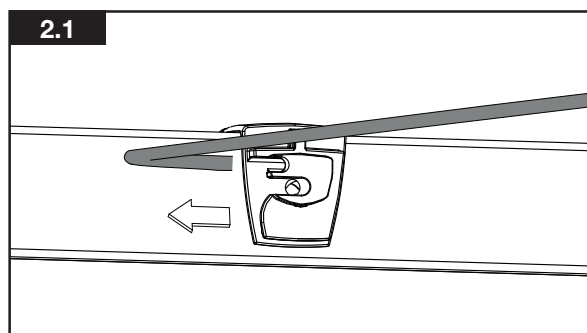

Pull line out from tensioner.

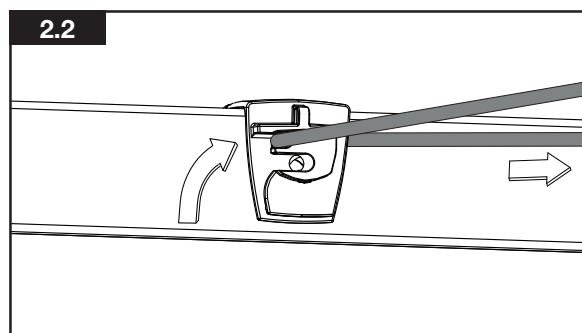

Undo line from tensioner path. Insert new line.

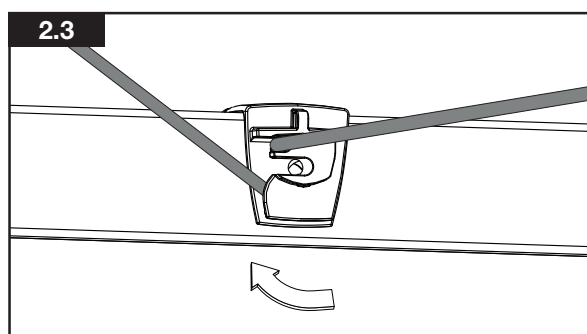

Swing the line back under the tensioner lip to secure.  
**TIP:** Keep pressure on bottom left edge to stop tension loss.

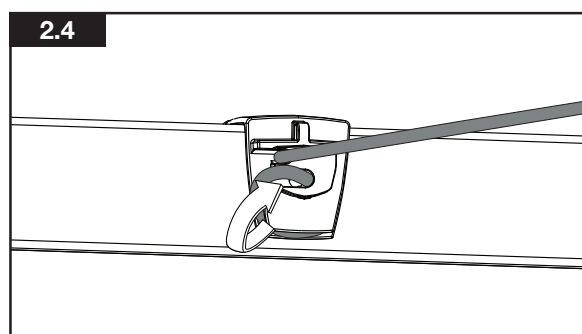

Feed line back into arm through central hole.  
Cut off excessive line if required prior to putting into arm.

## Step 2 – Replacing New Line

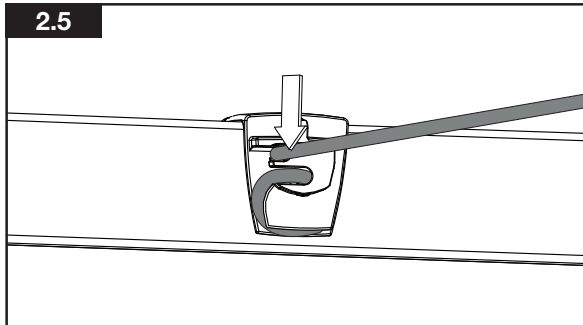

Push line firmly into arm to give a flush result.

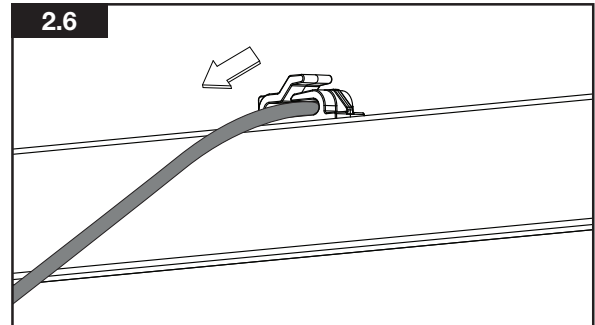

Feed line through clip on top of arm until you return to the tensioner arm.

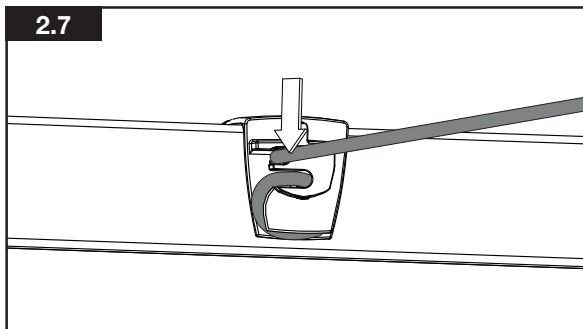

Refit line into tensioner as done previously.  
Ensure line is tensioned.



Fold hoist up and down to ensure hoist is not over tensioned and the lower cross engages with the locking collar

## Hills Warranty

1. Hills provides consumers with the following warranty in relation to this Product, in addition to complying with the requirements of any relevant legislation, including the Competition and Consumer Act 2010 (Cth) in Australia and the Consumer Guarantees Act 1993 in New Zealand (the **Acts**), except where a New Zealand consumer acquires the relevant Product for the purposes of a business.
2. In this warranty, we have used the following definitions:
  - (a) **Hills, our or we** means Hills Holdings Limited (ABN 35 007 573 417) of 159 Port Road Hindmarsh South Australia 5007;
  - (b) **Products** means the following goods manufactured by Hills (including products manufactured for Hills by its contract manufacturers): **Hills Rotary Folding Hoist Polycore Replacement Line;**
  - (c) **Material** means a material or component used by Hills in the manufacture of the Products;
  - (d) **Warranty Period** means 1 year from the date of purchase of the relevant Product. If the Product or part (as the case may be) is repaired or replaced, there will be no extension to the original warranty period; and
  - (e) **Workmanship** means the handling, assembly and manufacturing processes performed by or on behalf of Hills in order to manufacture the Products.
3. Hills warrants that for the duration of the Warranty Period, all Products will be free of faults arising from defects in Workmanship or Materials, on the terms and conditions set out in this warranty.
4. Hills undertakes that if during the Warranty Period any Product, or any part of a Product, has failed to operate correctly due to faulty Workmanship or defective Material, it will repair or replace the Product or part (as the case may be) free of charge provided that the following procedure is met:
  - (a) The consumer must contact Hills upon becoming aware of any defect to a Product. The contact details for Hills are set out in this warranty and under the heading "Hills Contacts".
  - (b) Following consultation with Hills, Hills will determine whether there is a defect, and if so Hills agrees to (at Hills' option):
    - i. in the case of goods – repair, replace or supply equivalent goods, or pay the cost of any of those remedies to the consumer; or
    - ii. in the case of services – supply the services again or pay the cost of having the services supplied again.
  - (c) If Hills requests the return of the applicable Product or part, Hills will be responsible for the collection and freight costs of returning that Product or part. The consumer agrees to assist Hills with any reasonable request to enable Hills to collect such Product or part.
  - (d) Hills also agrees to be responsible for the freight costs to deliver any new Product or replacement part to the consumer.

5. This warranty is in addition to any non-excludable legal rights or remedies conferred on the consumer under any applicable Act and any similar laws. To the extent permitted by law, Hills' liability for any non-excludable condition or warranty is limited to rectifying any defect at its option, as set out in paragraph 4(b).
6. Subject to the requirements of any applicable Act or legislation and to the extent permitted by law, no liability (whether expressed or implied) of any nature whatsoever, is accepted by Hills for any consequential loss, damage or injury arising as a result of any fault in the Products.
7. This warranty does not extend to damage to Products which occurs during transit or transportation, or which is caused by any abuse, accident or improper installation, connection, use, adjustment or repair or use of goods otherwise than in accordance with instructions issued by Hills.
8. The warranty on Products is waived if any addition or attachment to the Products do not have Hills' specific approval or are not sold as Hills products. The Products are designed to perform specific tasks under established test loads and unauthorised attachments may produce stresses for which the design is not appropriate.
9. The following applies to consumers who purchased a relevant Product in Australia:

Our goods come with guarantees that cannot be excluded under the Australian Consumer Law. You are entitled to a replacement or refund for a major failure and compensation for any other reasonably foreseeable loss or damage.  
You are also entitled to have the goods repaired or replaced if the goods fail to be of acceptable quality and the failure does not amount to a major failure.

## Hills Contacts

We are committed to providing you with complete customer satisfaction. If you have any questions or comments about our products or services please contact your nearest customer service centre during their local business hours:

### **Australia**

1300 300 564  
info@hills.com.au

### **New Zealand**

09 262 3052  
sales@hills.co.nz

### **United States**

877 534 1371 (Eastern)  
gsutterlin@verizon.net

### **Europe**

+44 (0) 118 973 8971 (UK)  
enquiries@greenergardensolutions.co.uk

### **South Africa**

021 442 1540  
info@stingray.co.za

### **Hills Websites**

**www.hills.com.au**

Hills Branded Products

**www.hillsholdings.com.au**

Hills Holdings Limited



Please retain this Product Manual. Record the following information for future reference.

Product Number (printed on header card): FD .....

Date of purchase: .....

Name and location of store: .....

.....



**Designed and tested under a Quality System that meets Hills demanding quality specifications.**

**Made in China**



**Hills Holdings Limited**  
A.B.N. 35 007 573 417

Issue October 2011  
PD1043c